

Energy efficiency class	-	A+	A+	A+
Energy efficiency index (EEI)	-	113	113	114
Seasonal Energy Efficiency of space heating ( $\eta_s$ )	%	74,5	74,5	75,3

**Note:** The values indicated in the above table are based on tests performed in accordance with UNE-EN 12815 with logs with no more than 18% humidity and pressure conditions as indicated in each case.

**Warning:** this appliance is designed and prepared to work with the types of fuel, degree of humidity of the fuel, fuel loads, fuel load frequencies, flue draught and system of installation indicated in this Instruction Book. Failure to respect these conditions may lead to problems with the appliance (deterioration, shorter useful life, etc.) which are not covered by the Lacunza warranty.

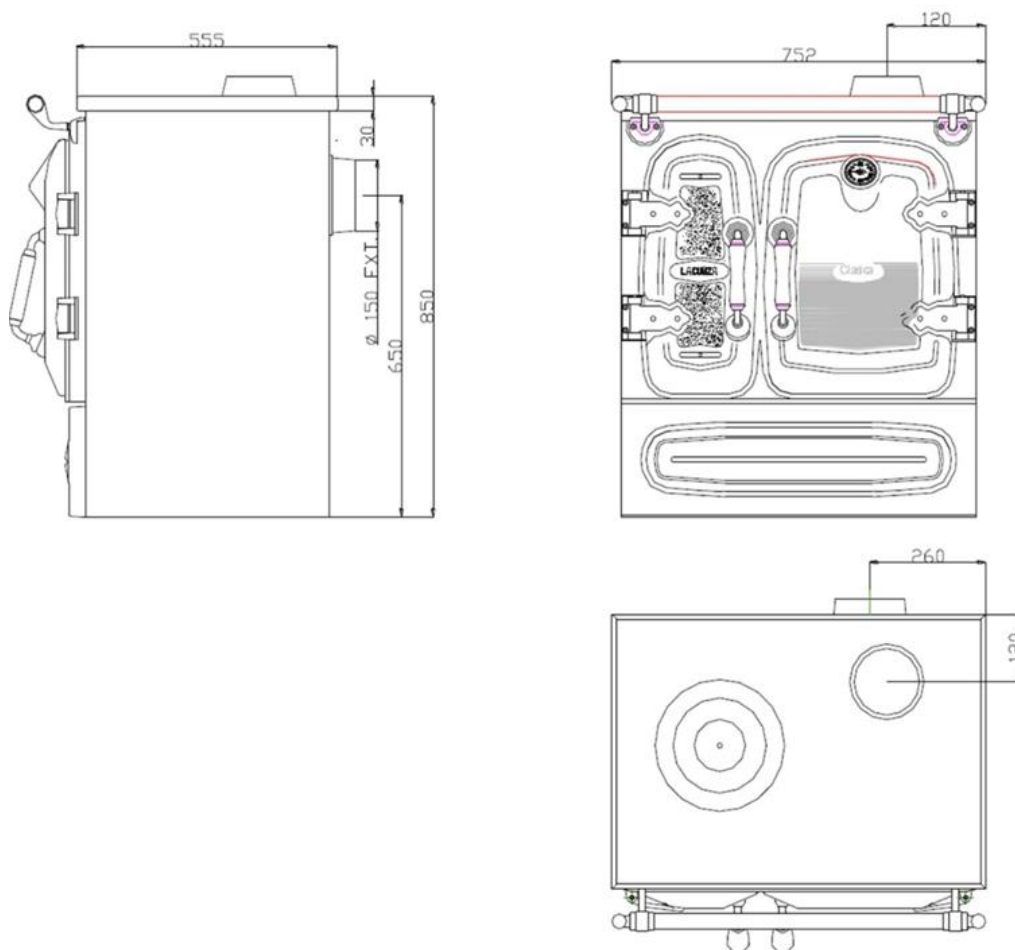

Figure No.1 - Dimensions of the Clásica 5T appliance in mm

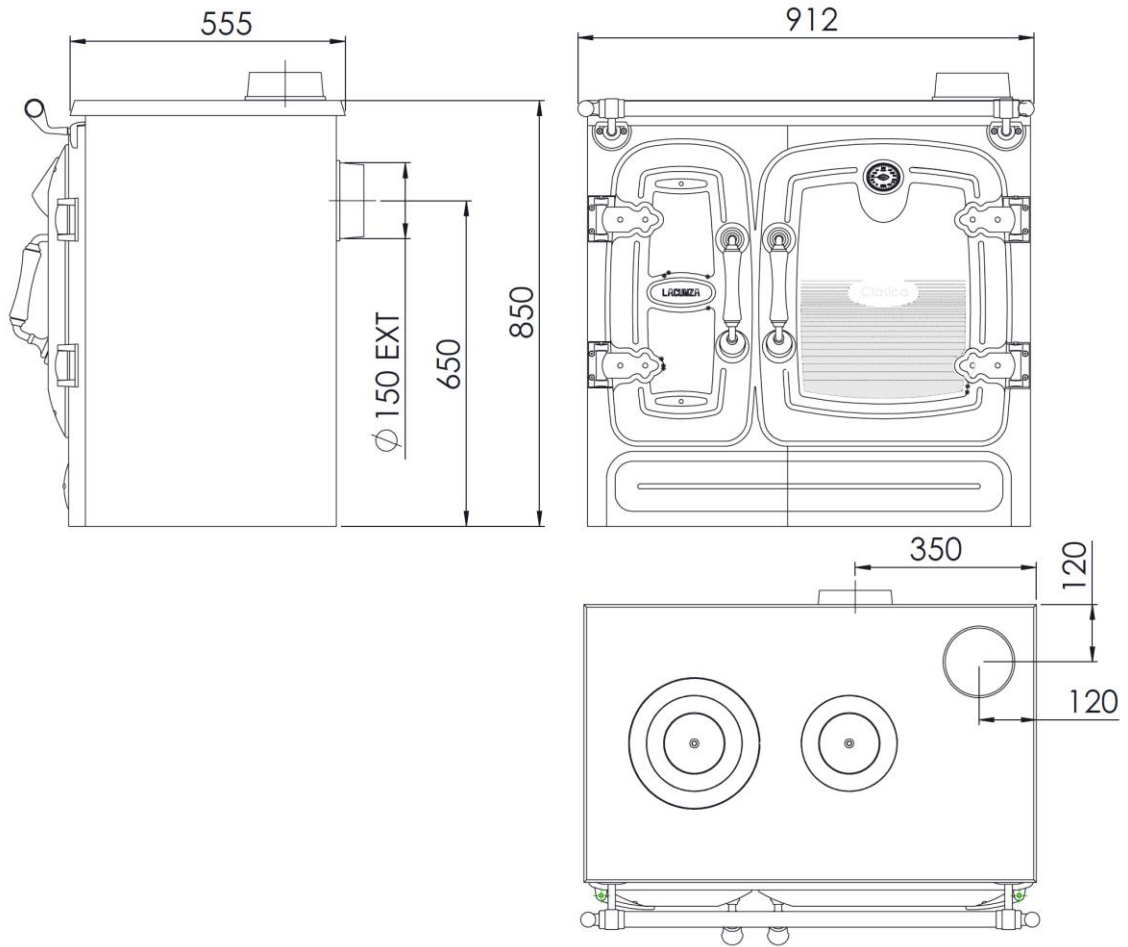

Figure No.2 - Dimensions of the Clásica 7T appliance in mm

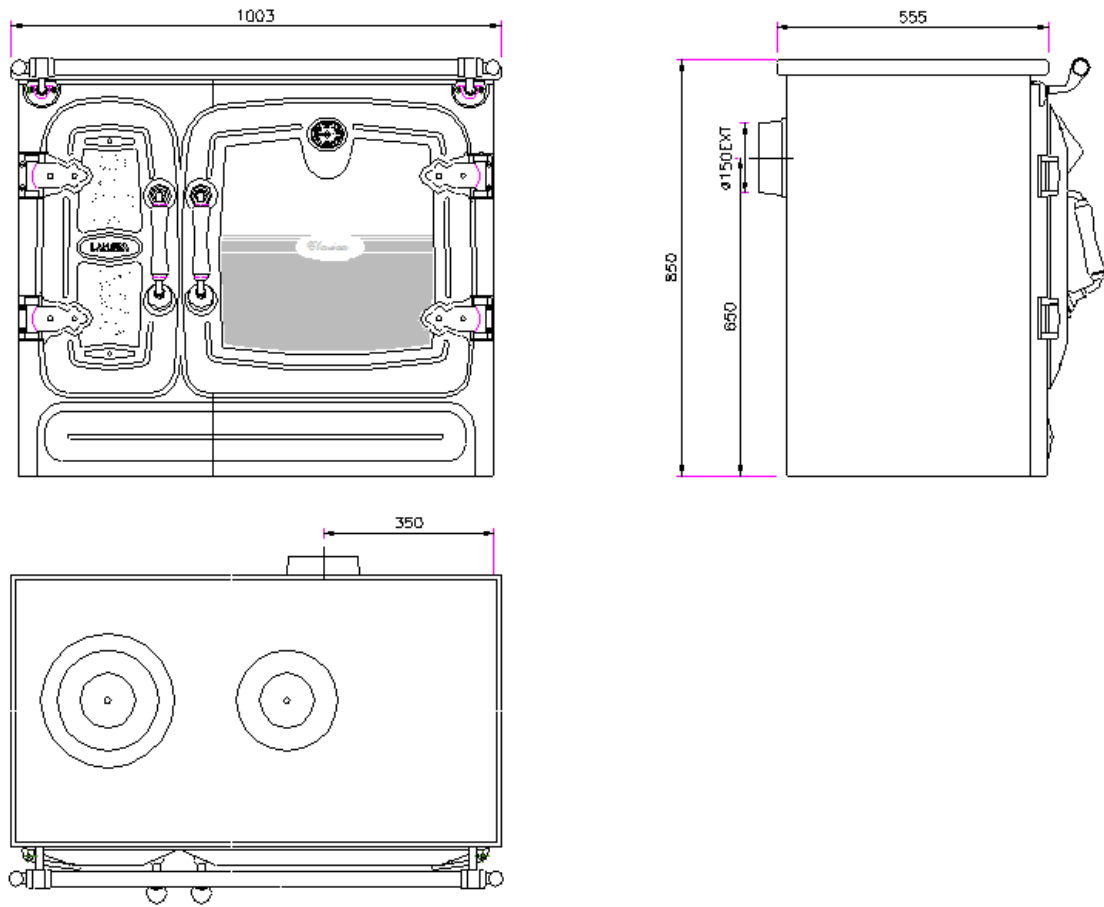

Figure No.3 - Dimensions of the Clásica 8T appliance in mm