

NOTES

MATERIAL - MILD STEEL
 FINISH - POWDERCOATED TEXTURED MATT BLACK

TO BE SUPPLIED WITH 5MM THK 'STRONG' MAGNETS,
 TO STOP AS MUCH FRICTIONAL MOVEMENT AS POSSIBLE

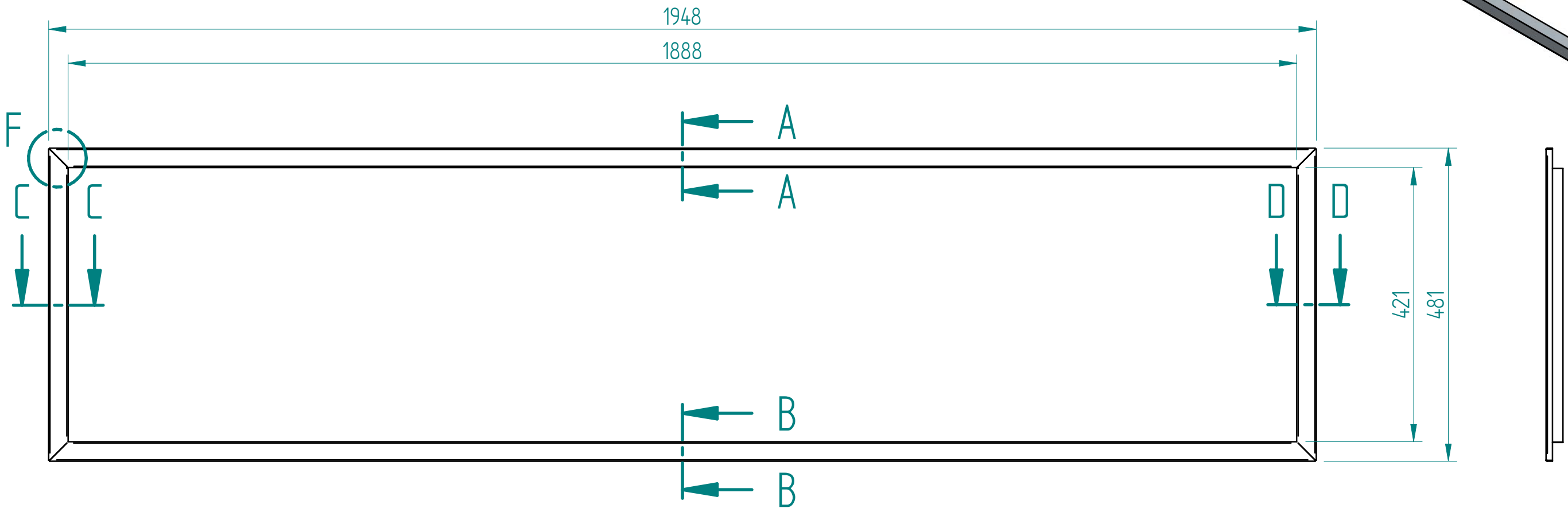
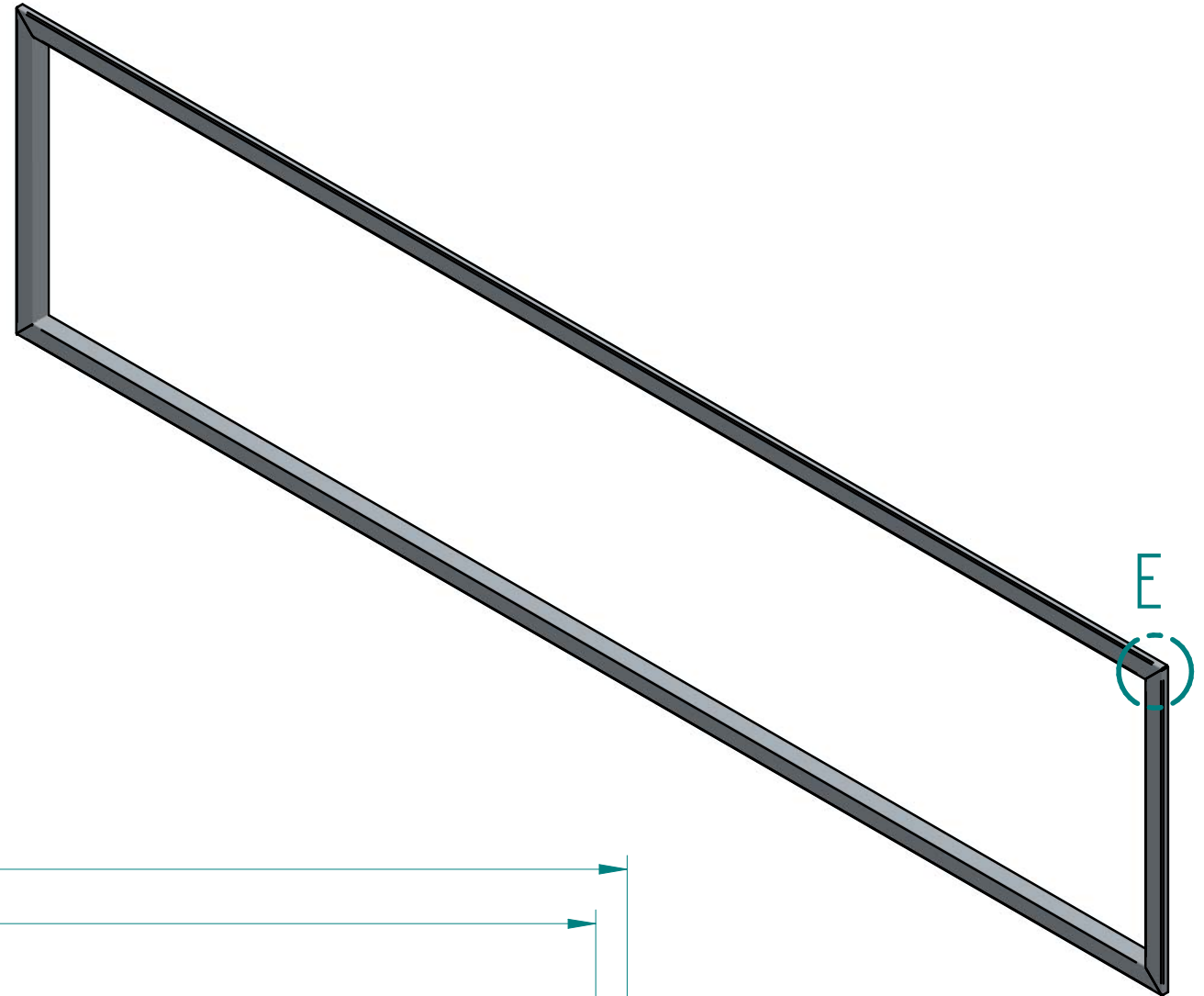

26 WAS 23	03/03/25	E
FIRST ISSUE	09/01/25	D

LOC.	CHANGE & ACTIONED BY	DATE	ISS.
USED ON NF1900			DRWN: PeterD
SCALE: NTS	MATL: SEE NOTES	DATE: 09/01/2025	FIN: SEE NOTES
			CHKD:



AVON TRADING
 PARK
 REID STREET
 CHRISTCHURCH
 DORSET BH23 2BT

PART No: F712306	ISS
DESC: TRIM ASSY	E

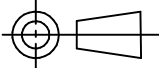

ALL DIMS IN MM
 DO NOT SCALE

ALL COMPONENTS TO BE FREE FROM SILICONE CONTAMINATION AND BURRS.
 TOLERANCES +/- 0.25 UNLESS OTHERWISE STATED. ORIGINAL PAGE SIZE A3

ALL INFORMATION REMAINS THE PROPERTY OF FOCAL POINT FIRES PLC.
 THE COPYING AND DISSEMINATION TO ANY OTHER PARTIES IS NOT
 PERMITTED WITHOUT EXPRESS PERMISSION OF THE ABOVE.